

Assembly

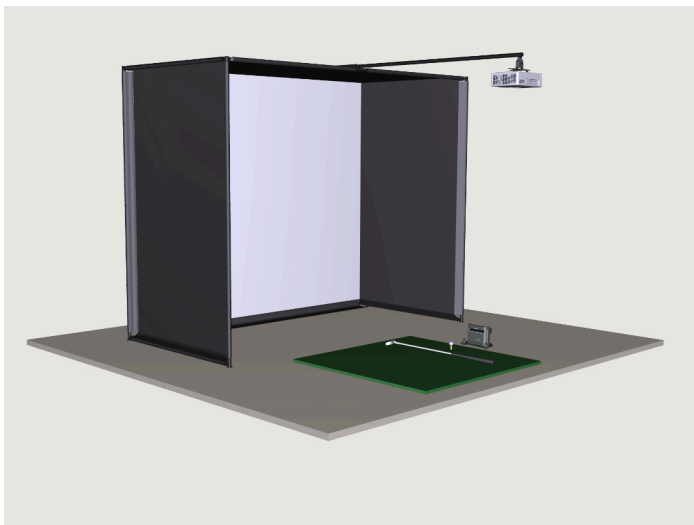

Step 1

This procedure will assist you with assembling the Golf Simulator Par 5 Short Enclosure.

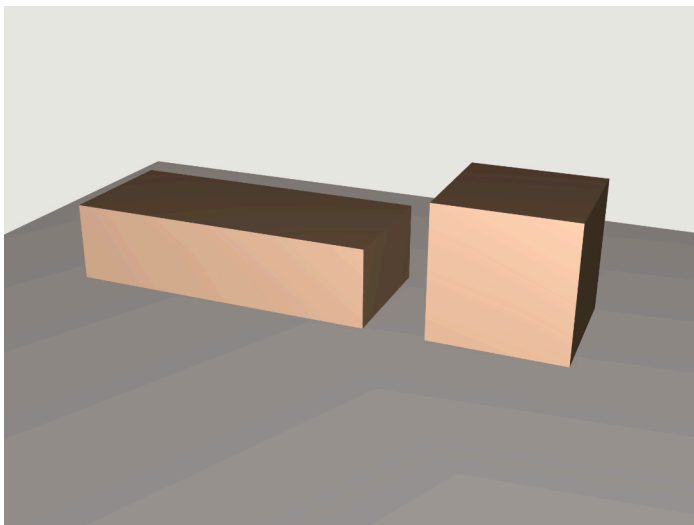

Step 2

Your Golf Simulator Par 5 Short Enclosure will come in 2 separate cartons: 1 long carton for the Metal Frame and 1 rectangular carton for the Enclosure Material with Screen. Please review the parts list and ensure you have all the equipment needed.

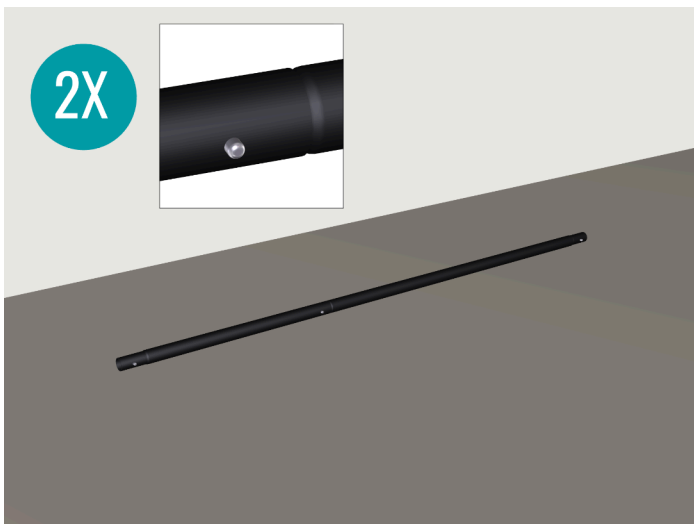

Step 3

The following steps will assist you with assembling the Upper Frame. Depress the pin on one end of (1) Pole (B). Insert the Pole into the female end of (1) Pole (D) as shown. Complete this step 2 times.

Assembly

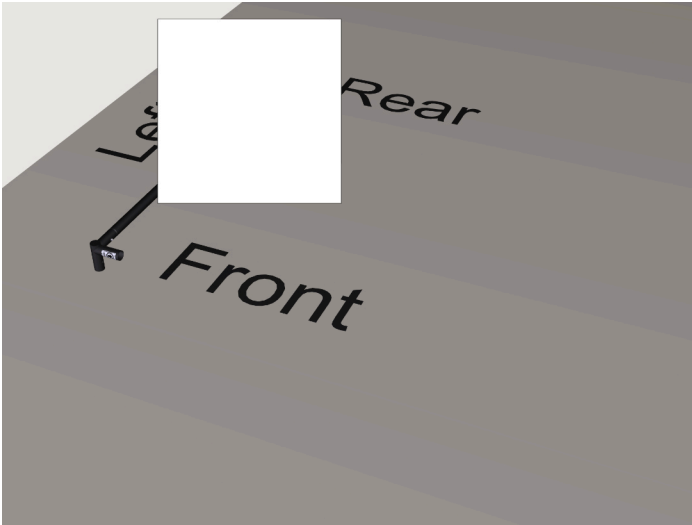

Step 4

For the Top Left Beam, depress the pins on both ends of the Pole Assembly (B, D). Slide (1) 105 Degree 3-Way Connector (1) over the front end and (1) 105 Degree 3-Way Connector (2) over the back end. Ensure the arrows on the Connectors are pointed toward the center as shown.

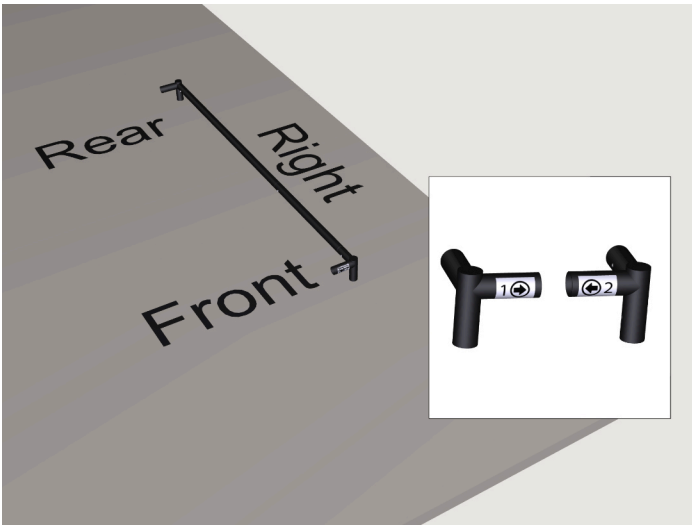

Step 5

For the Top Right Beam, depress the pins on both ends of the Pole Assembly (B, D). Then, slide (1) 105 Degree 3-Way Connector (2) over the front end and (1) 105 Degree 3-Way Connector (1) over the back end. Ensure the arrows on the Connectors are pointed toward the center as shown.

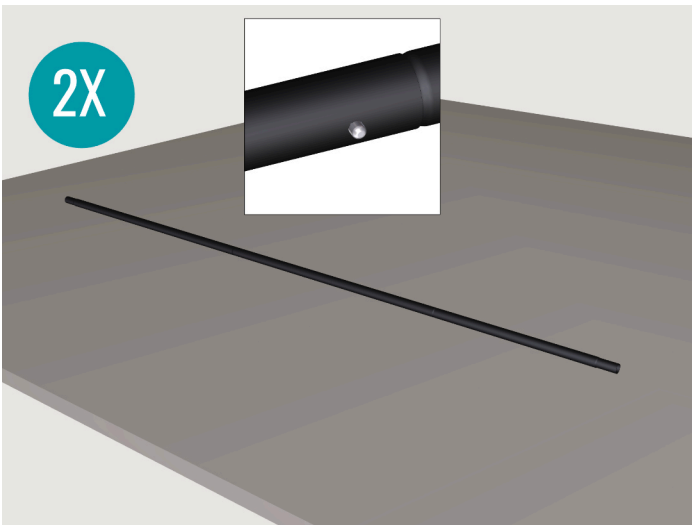

Step 6

Depress the pins on both ends of (1) Pole (B). Insert the Pole into the female ends of (2) Poles (A) as shown. These Poles are for the top Front and Rear of the Enclosure. Complete this step 2 times.

Assembly

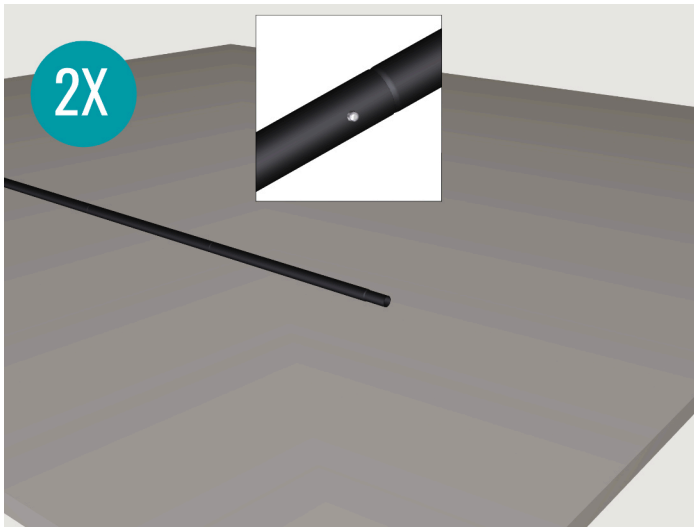

Step 7

Depress the pin on the end of the Pole (A). Insert the Pole into the female end of (1) Pole (A) as shown. Complete this step 2 times.

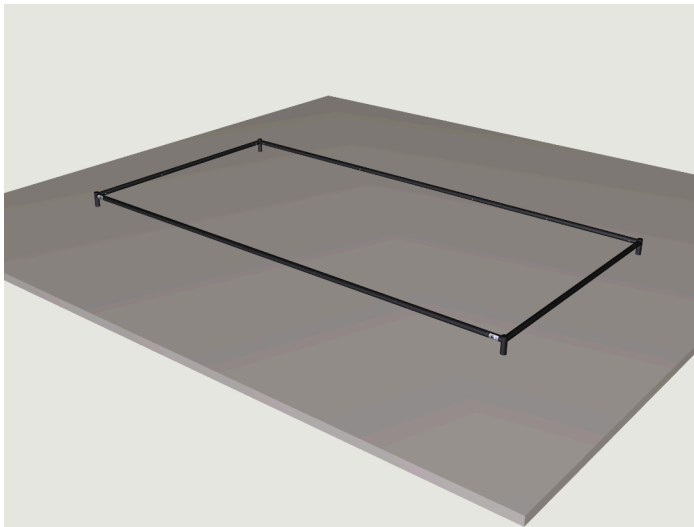

Step 8

Depress the pins on the ends of the Pole Assemblies (A, B, A, A) and insert them into the 3-Way Connectors as shown.

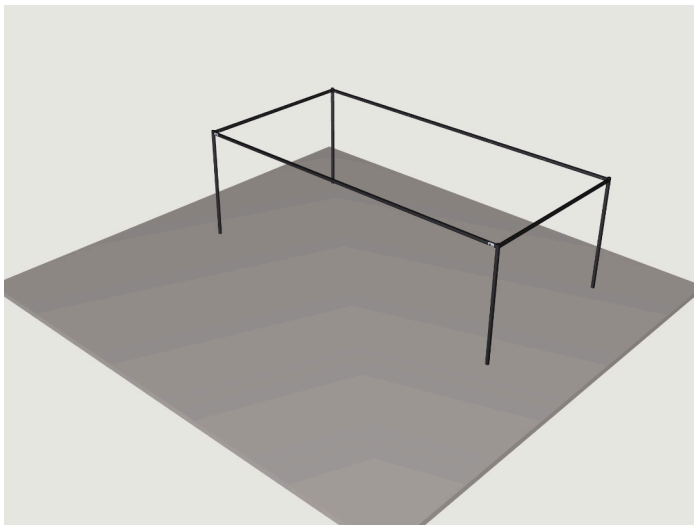

Step 9

Depress the pins on the male ends of (4) Poles (A) and insert them into the 3-Way Connectors as shown.

Assembly

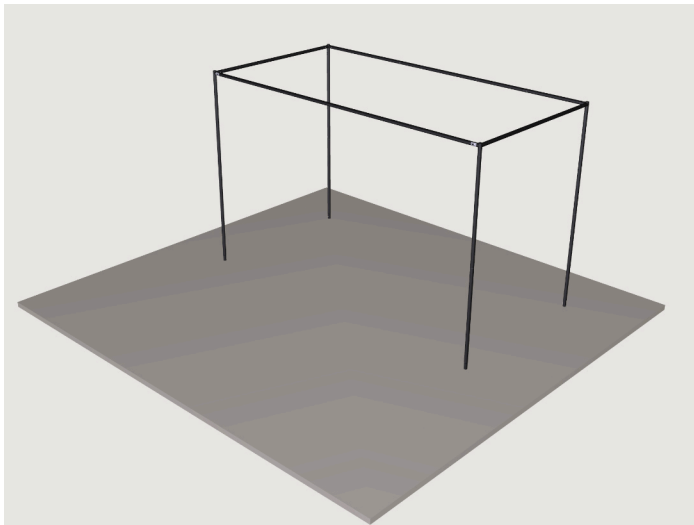

Step 10

Depress the pins on the male ends of (4) Poles (B) and insert them into the ends of each Pole (A) as shown.

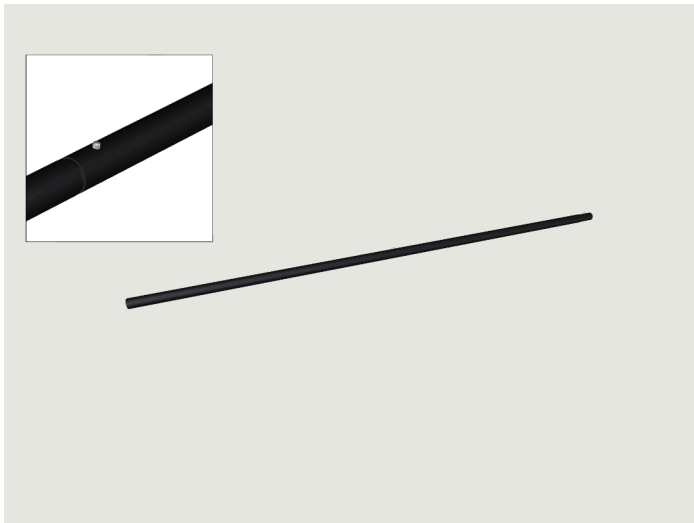

Step 11

Depress the pin on the end of (1) Pole (A) and insert it into the female end of (1) Pole (A) as shown.

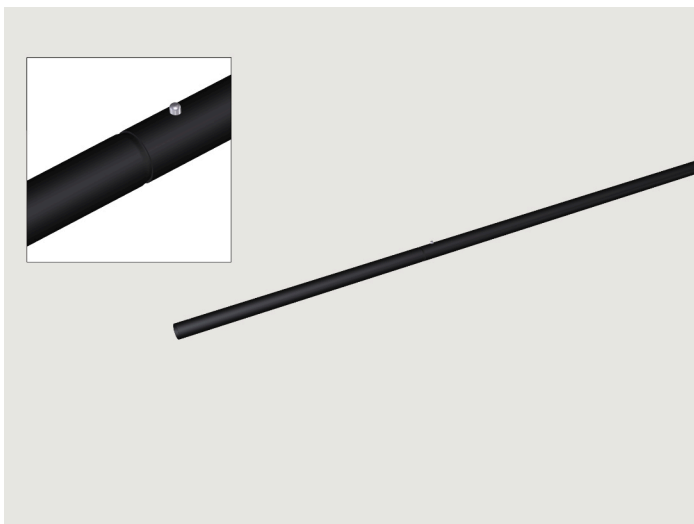

Step 12

Depress the pin on the end of (1) Pole (C) and insert it into the female end of Pole (A) as shown.

Assembly



Step 13

Depress the pin on the end of (1) Pole (F) and insert it into the female end of Pole (C) as shown.

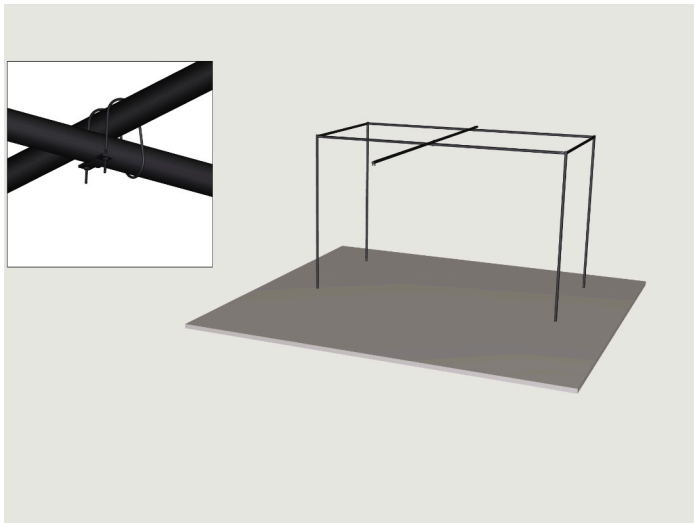

Step 14

Attach (2) Crossover Clamps (X) to the Frame Assembly and mount the Pole Assembly (A, A, C, F) as shown.

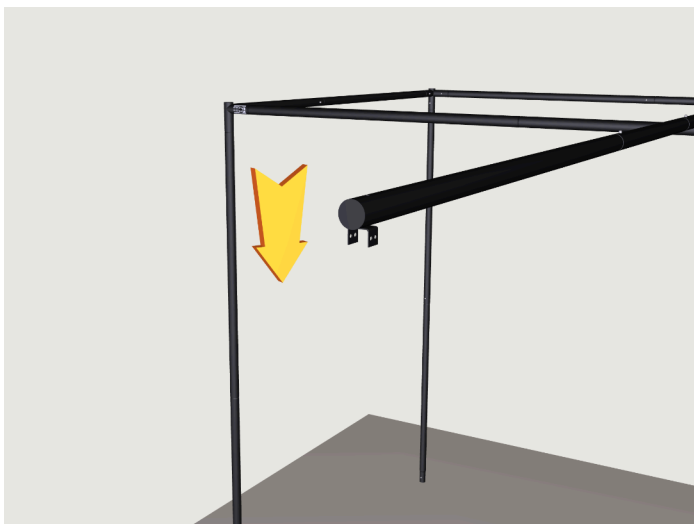

Step 15

Note: Be sure the square gimbal piece of Pole (F) is oriented to face downward once the Pole Assembly is installed.

Assembly

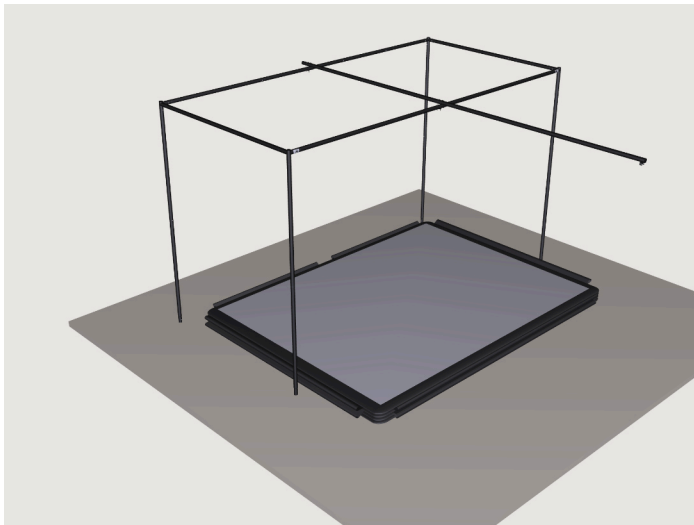

Step 16

Place the Enclosure Material with Screen in the center of your enclosure area. Spread the black material out so the bottom of the Screen is identifiable. The white side should face the user when it is successfully installed. **_x000D_ WARNING:** The Enclosure Material with Screen is not the hitting Screen.

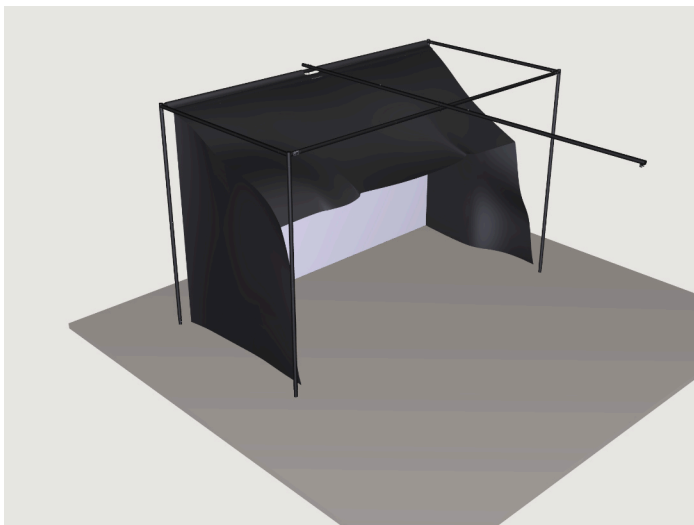

Step 17

Secure the top rear edge of the Enclosure Material to the Upper Frame using the hook and loop attachments. Start at the rear before moving on to each side.

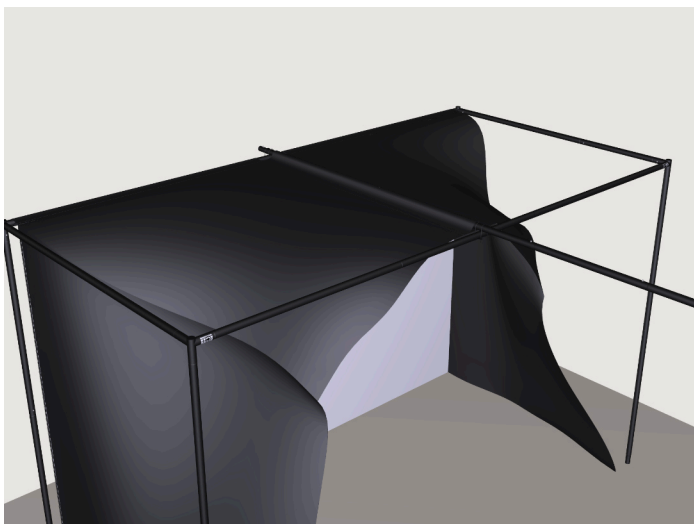

Step 18

Secure the Enclosure Material to the Projector Pole using the hook and loop attachments. **_x000D_ Note:** Leaving off the last 1/4 of the hook and loop attachment on the Projector Pole will allow you to hook and loop the impact screen on the inside of the Enclosure.

Assembly

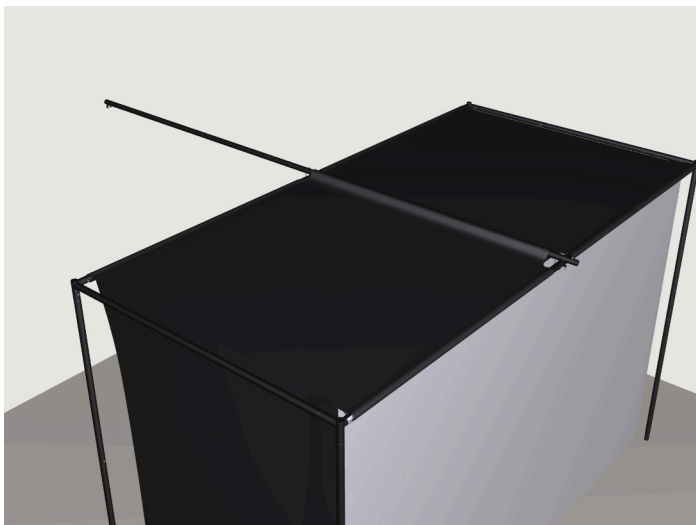

Step 19

Secure the Enclosure Material to the Upper Front Frame using the hook and loop attachments.

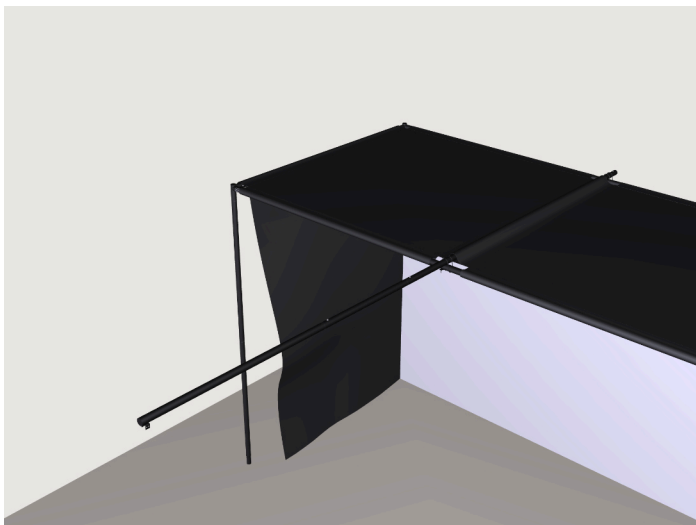

Step 20

Secure the Enclosure Material to the Upper Left Frame using the hook and loop attachments.

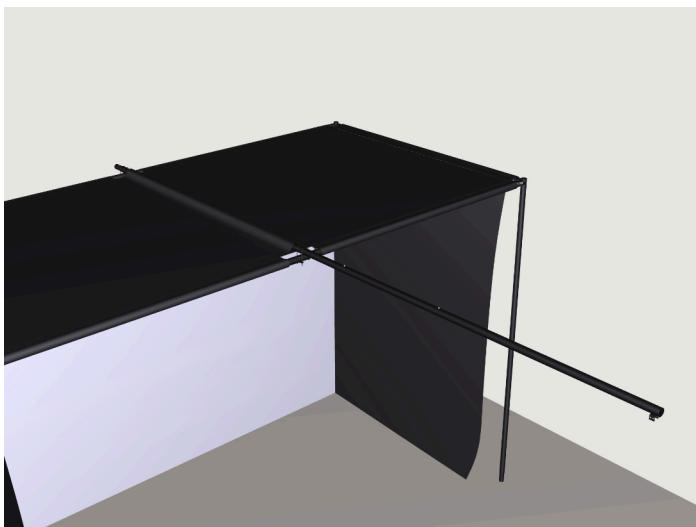

Step 21

Secure the Enclosure Material to the Upper Right Frame using the hook and loop attachments. _x000D_ Note: Pull the fabric tight by grabbing the Material from the underside and twisting it over the top. If the hook and loop struggle to meet, pull firmly and twist from top to bottom to bring the hook and loop up easier.

Assembly

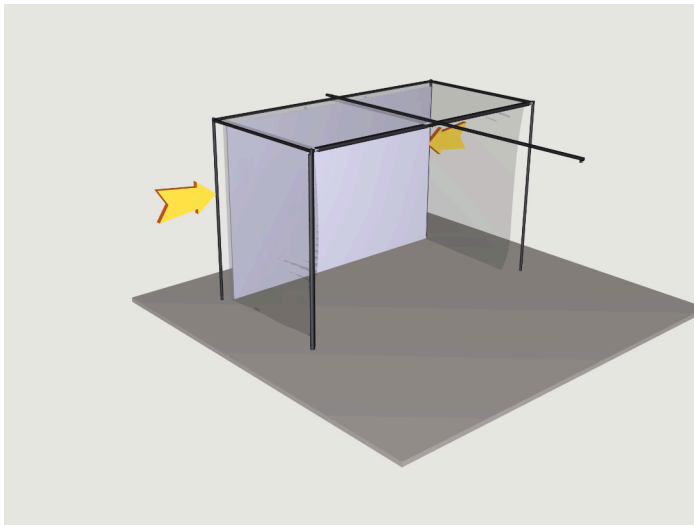

Step 22

Attach the Impact Screen to the inside of the Enclosure using the hook and loop attachments. Push the Impact Screen outward, and push the outside of the Enclosure inward.

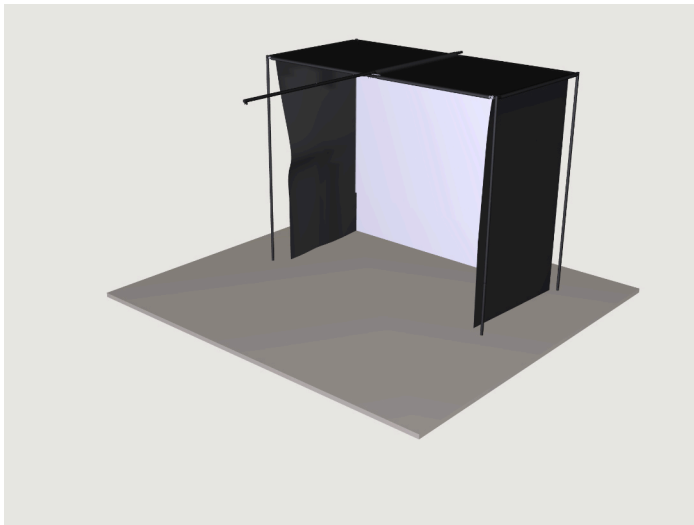

Step 23

Lift one side of the Assembly and depress the pins on Poles (B). Insert the Poles into the female end of (2) Poles (A). Lift the other side of the Assembly and depress the pins on Poles (B). Insert the Poles into the female end of (2) additional Poles (A) as shown.

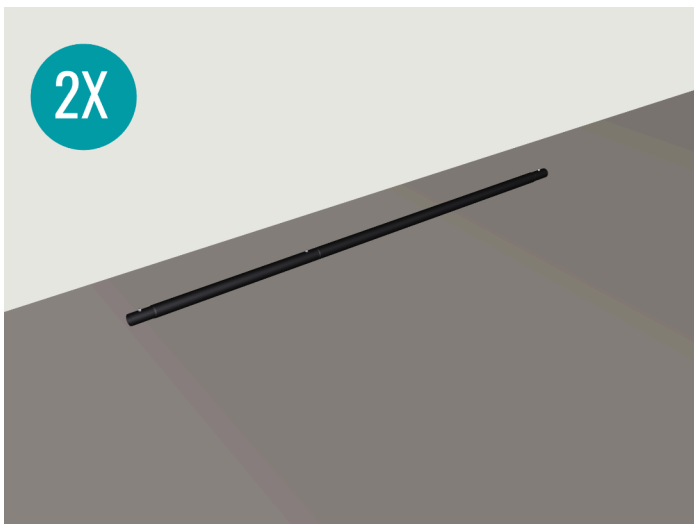

Step 24

Depress the pin on one end of (1) Pole (B) and insert it into the female end of (1) Pole (D). Complete this step 2 times.

Assembly

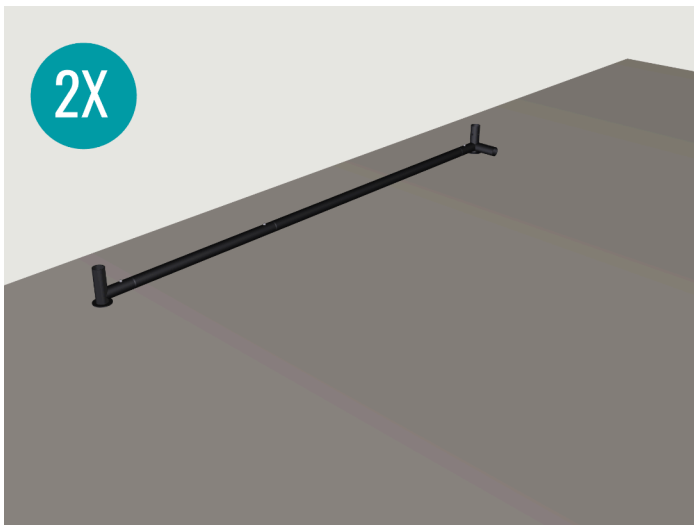

Step 25

Depress the pins on both ends of the Pole Assembly (B, D). Insert Pole (B) into (1) 3-Way Feet Connector (5) and Pole (D) into (1) 2-Way Feet Connector (4) as shown. Ensure the 3-Way Feet Connector faces inward for the structure. Complete this step 2 times.

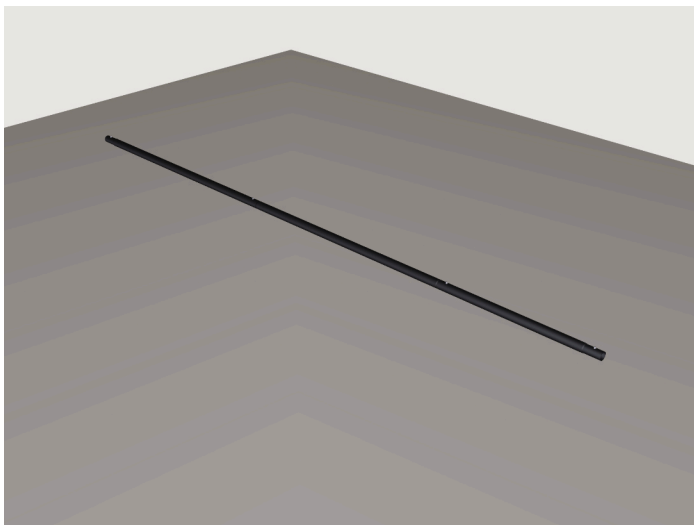

Step 26

Depress the pins on both ends of (1) Pole (B). Insert the Pole into the female ends of (2) Poles (A) as shown.



Step 27

Depress the pin on the male end of Pole (A). Insert the Pole into the female end of (1) Pole (A) as shown.

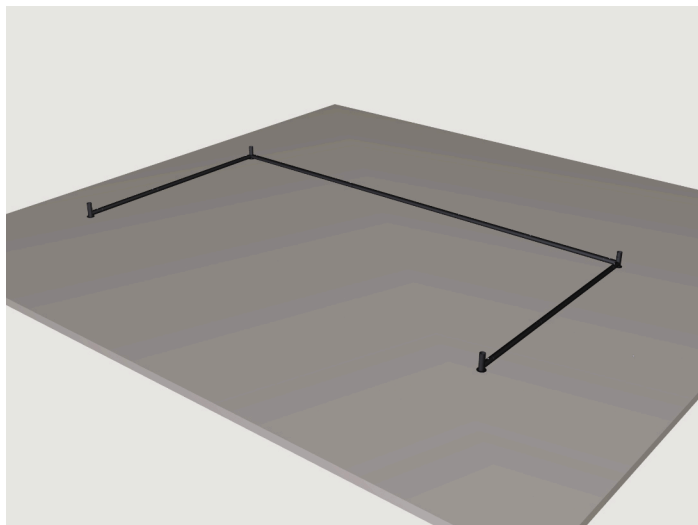

Step 28

Depress the pins on the ends of the Pole Assembly (A, B, A, A) and insert them into the 3-Way Feet Connectors as shown.

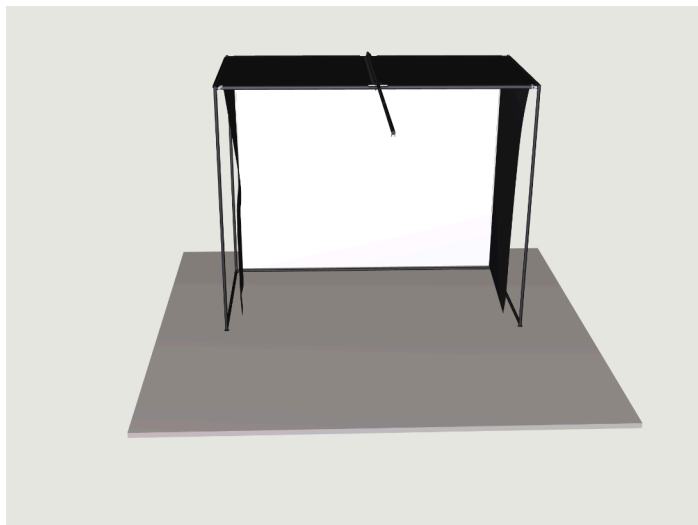

Step 29

Attach the Enclosure to the Base Assembly as shown. Insert one Pole at a time and ensure the push pins are secured when complete.

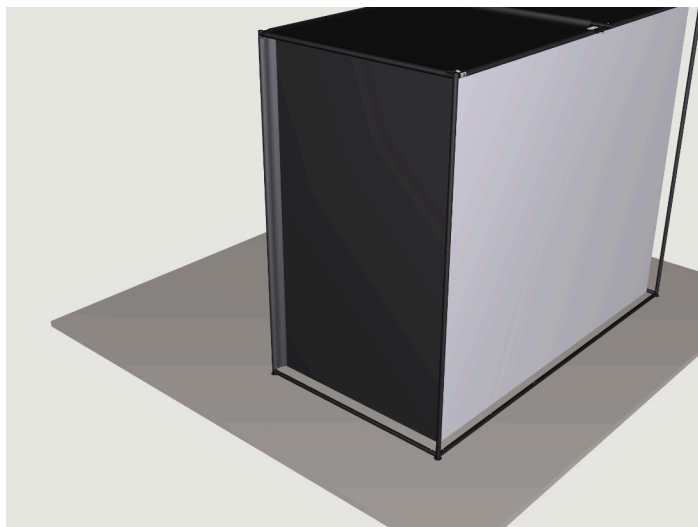

Step 30

Secure the Enclosure Material to the Right Front Frame using the hook and loop attachments.

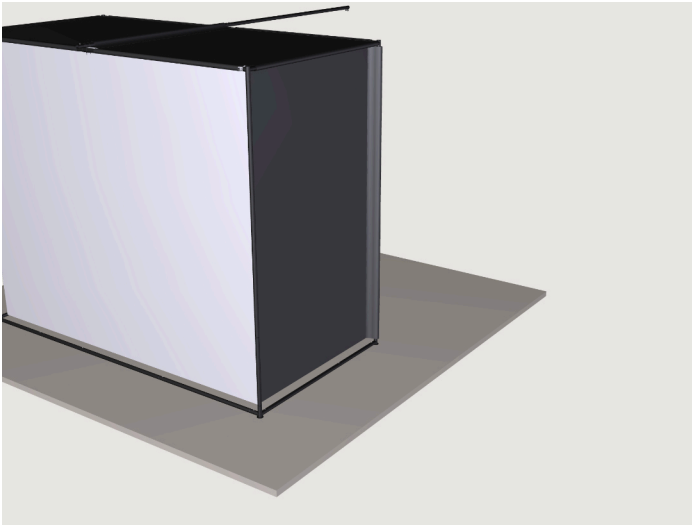

Step 31

Secure the Enclosure Material to the Left Front Frame using the hook and loop attachments.

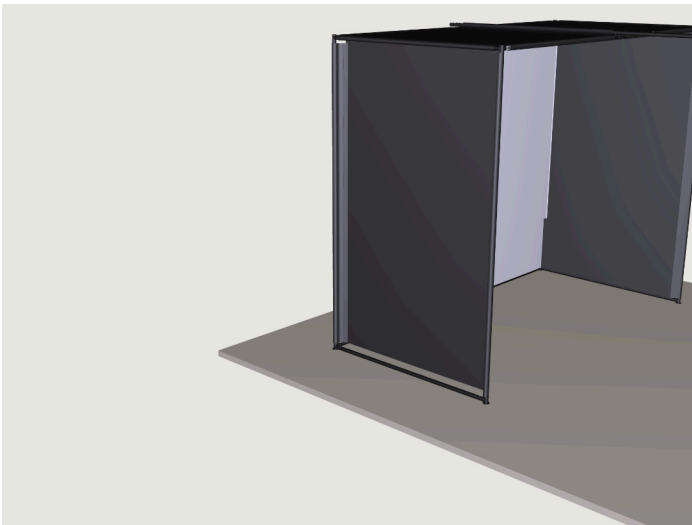

Step 32

Secure the left side of the Enclosure Material to the Left side of the Frame using the hook and loop attachments.

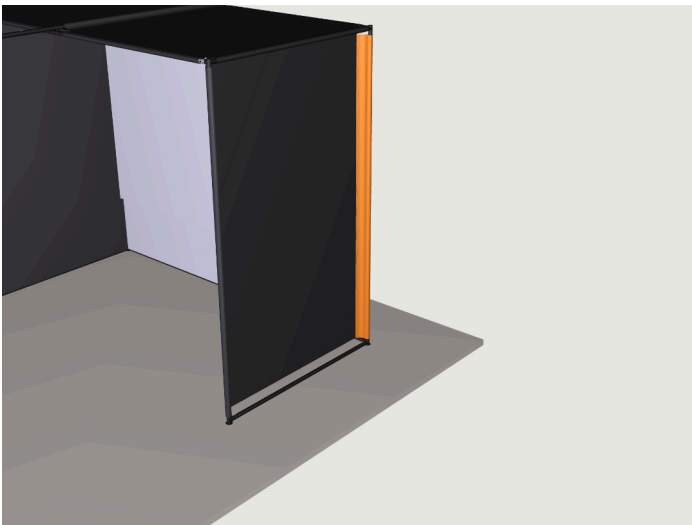

Step 33

Secure the right side of the Enclosure Material to the Right side of the Frame using the hook and loop attachments.

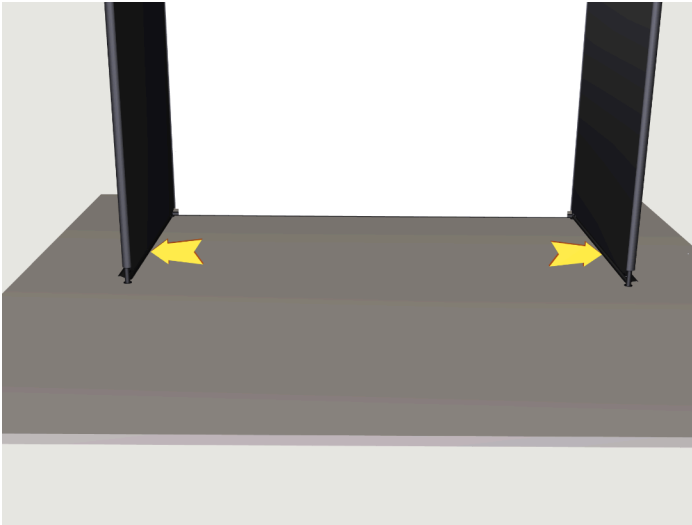

Step 34

Wrap the bottom of the Enclosure Material underneath the base of the Frame as shown. _x000D_ Note: The rear exterior bottom may not connect completely. This will not jeopardize the integrity of the Enclosure, as long as the majority of the strip is wrapped.

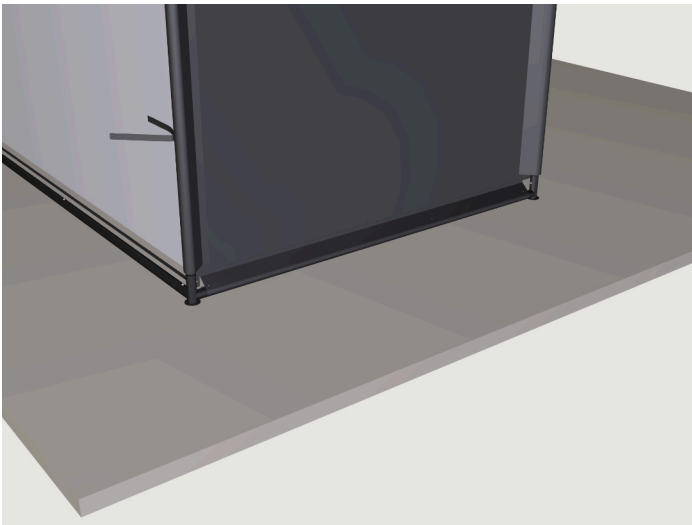

Step 35

Secure the Enclosure Material to the Lower Left Frame using the hook and loop attachments.

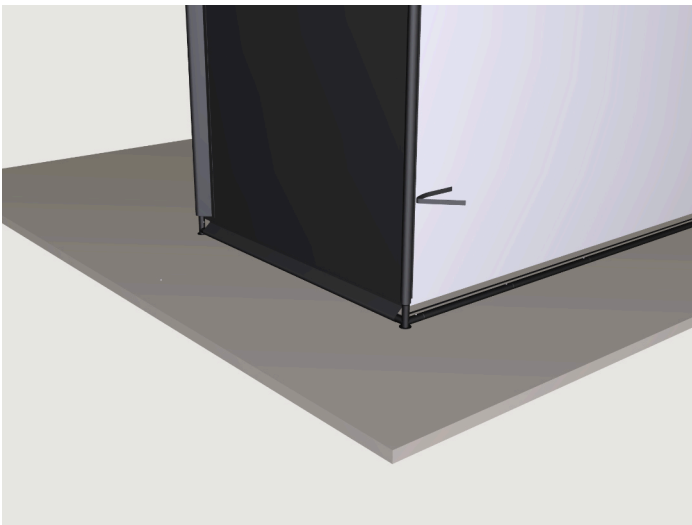

Step 36

Secure the Enclosure Material to the Lower Right Frame using the hook and loop attachments.

Assembly

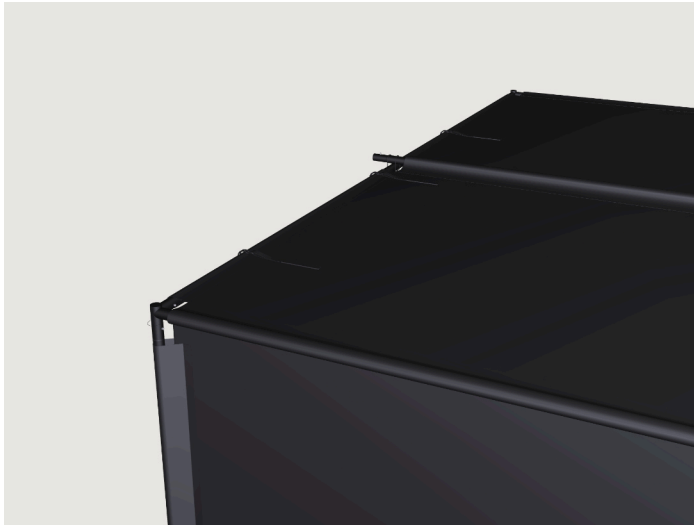

Step 37

Slide (3) Clips onto the Straps on the top of the Enclosure Material with Screen. Connect the Straps and secure the Clips onto the rear Pole Assembly.

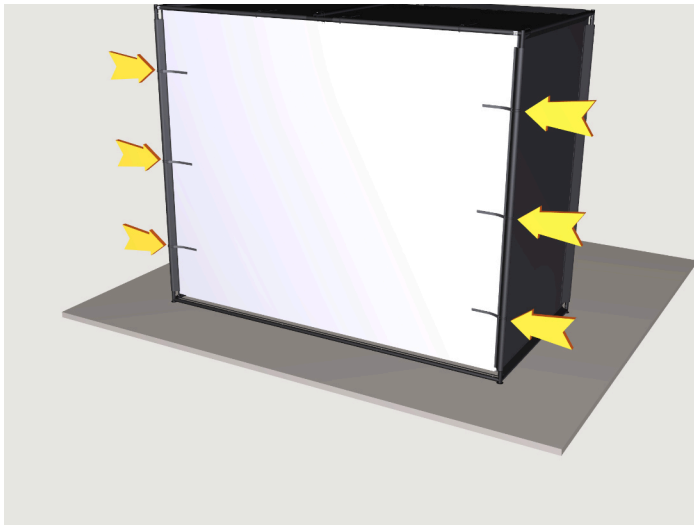

Step 38

Slide (6) Clips onto the Straps on the backside of the Enclosure Material with Screen. Connect the Straps and secure the Clips onto the side Pole Assembly.

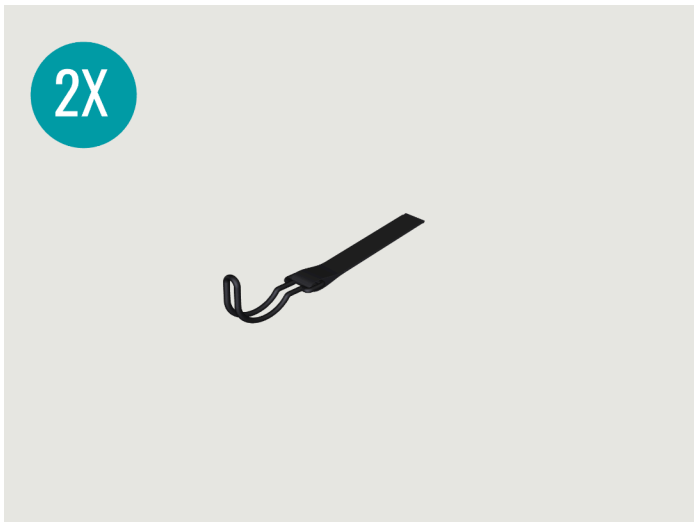

Step 39

Slide (1) Hook and Loop through (1) Clip as shown. Complete this step 2 times.

Assembly

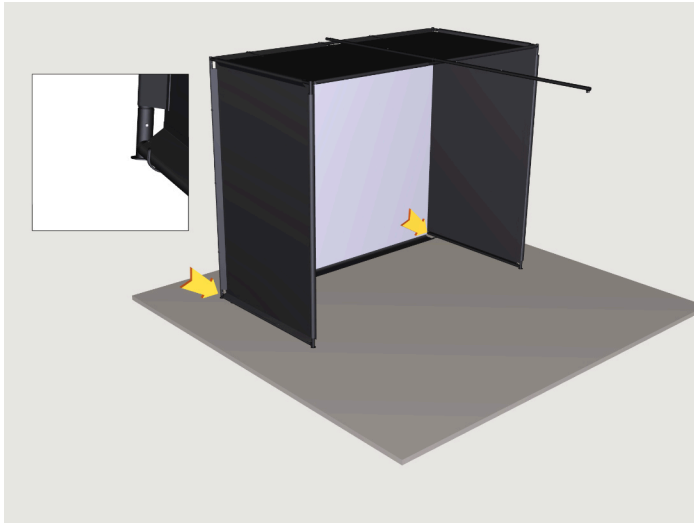

Step 40

Attach the bottom Material Clips to the Frame.

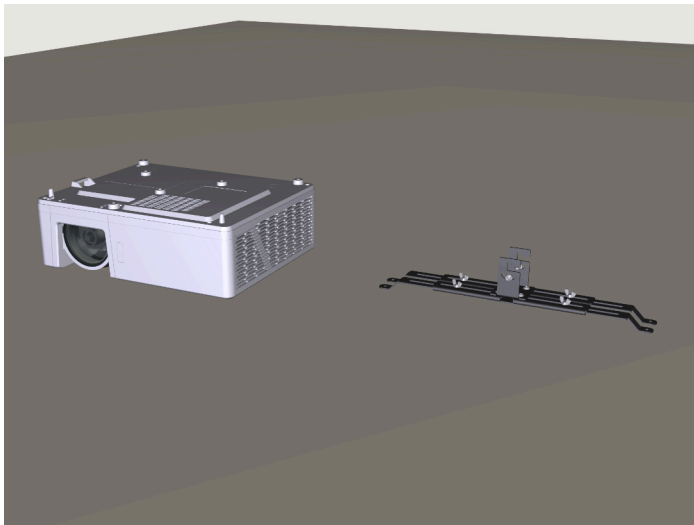

Step 41

The following steps will assist you with the Projector installation. `_x000D_` Note: The installations will vary based on Projector and Projector Mount.

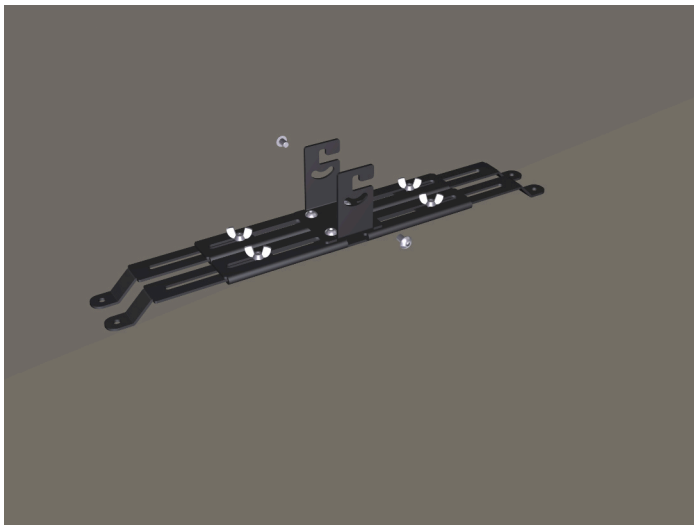

Step 42

You will need to prepare the bracket to support the Projector. One arm is redundant and needs to be removed. You can loosen and remove the Projector Mount Screws on the hinge to access the screws beneath it more easily.

Assembly

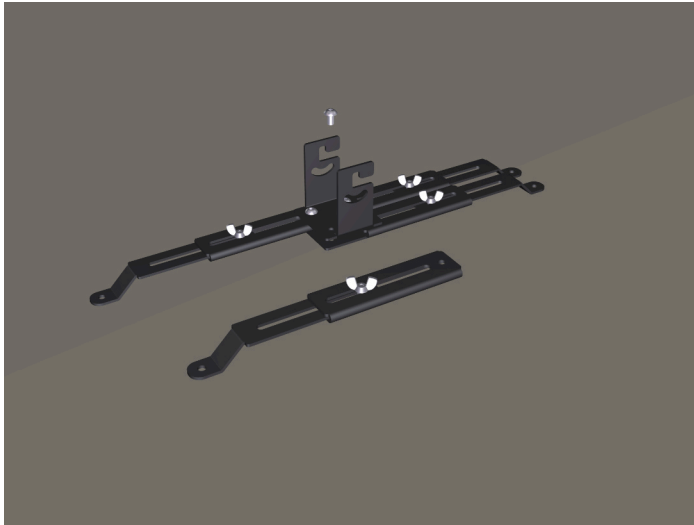

Step 43

One arm must be removed. Remove the indicated Projector Mount Screw at the top to remove the arm.



Step 44

Remove the indicated Wingnut and Projector Mount Screw to remove the Long Attachment as shown.



Step 45

Rotate the Long Attachment 180 degrees and slide it back into the Bracket. Tighten the Wingnut and Projector Mount Screw in the approximate position shown to secure the Long Attachment.

Assembly

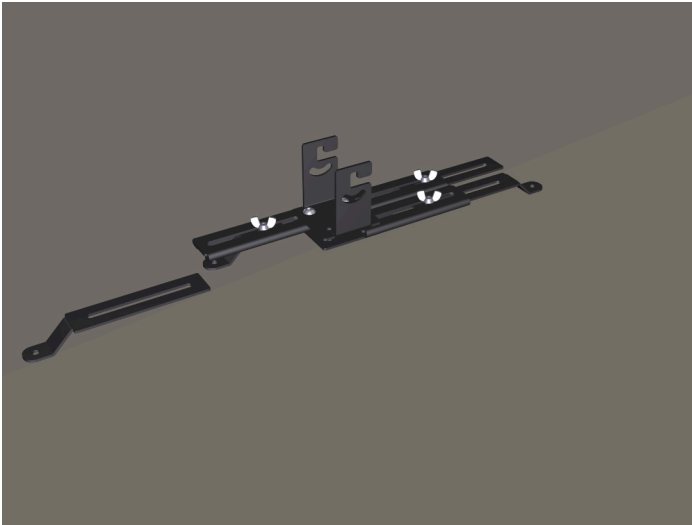

Step 46

Remove the indicated Wingnut and Projector Mount Screw to remove the Long Attachment. Slide in the Short Attachment and secure it using the Wingnut and Screw in the approximate position shown.

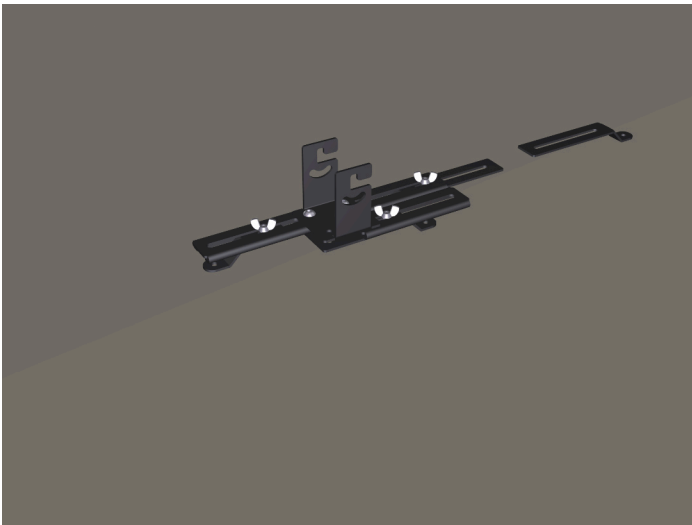

Step 47

Remove the indicated Wingnut and Projector Mount Screw to remove the Long Attachment. Slide in the Short Attachment and secure it using the Wingnut and Screw in the approximate position shown.

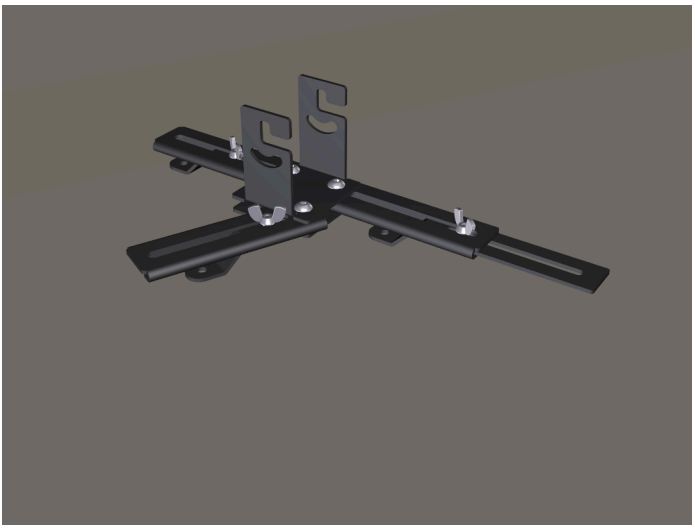

Step 48

Loosen the indicated Projector Mount Screw to adjust the arm by roughly 110 degrees in the forward position. Once adjusted, retighten the Screw.

Assembly



Step 49

The Projector Mount will attach to the indicated holes on the Projector.

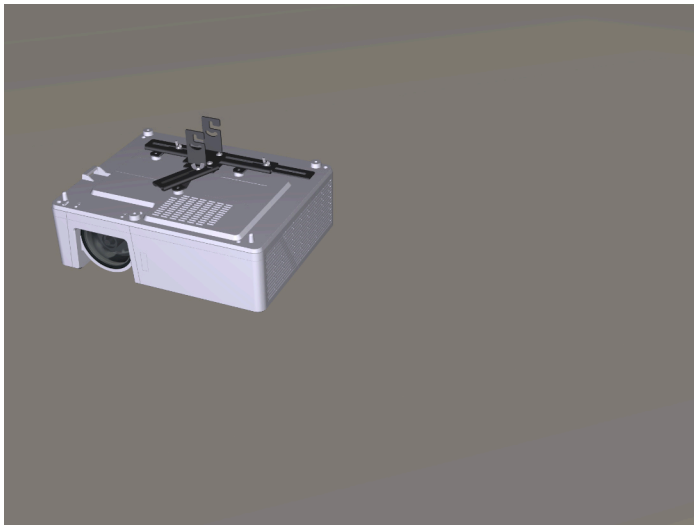

Step 50

Place the Projector Mount onto the Projector.



Step 51

Adjust the arms on the Projector Mount as needed to line up all connection points.

Assembly



Step 52

Install the Projector Mount onto the Projector using (3) Projector Mount Screws and (3) Washers.



Step 53

Align and attach the Mounting Bracket to the gimbal mount on Pole (F) using (4) Projector Mount Screws.

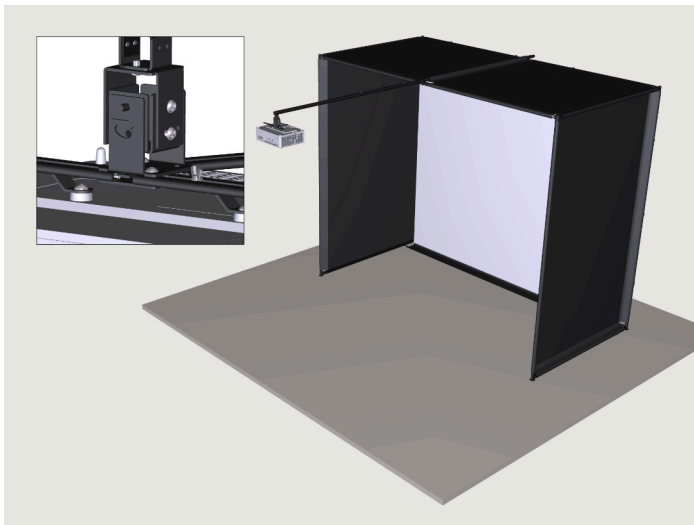

Step 54

Hang the Projector Mount onto the Mounting Bracket as shown.

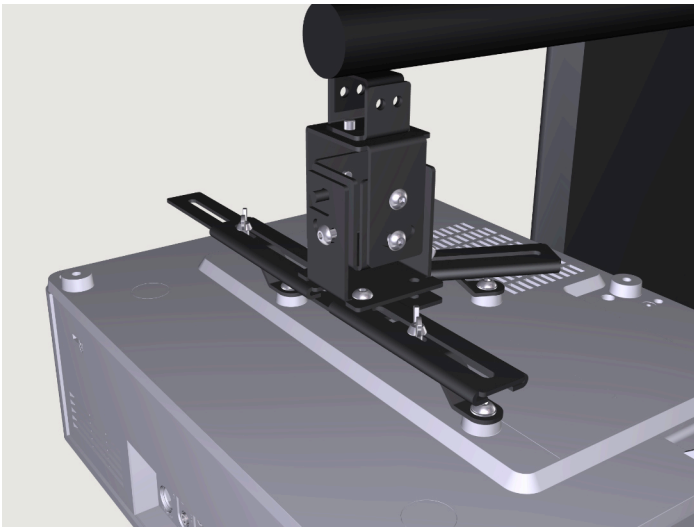

Step 55

Attach the Projector Mount to the Mounting Bracket using (2) Projector Mount Screws.



Step 56

The following steps will walk you through the positioning of the SkyTrak+ and Shield. _x000D_ Note: The SkyTrak+ and Shield are not included with your purchase of the Golf Simulator Par 5 Short Enclosure.



Step 57

Fasten (3) Plastic Leveling Feet onto the Shield using (3) M8 Nylon Wing Nuts. Adjust the Leveling Feet to position the SkyTrak+ at the same height as the mat.

Assembly

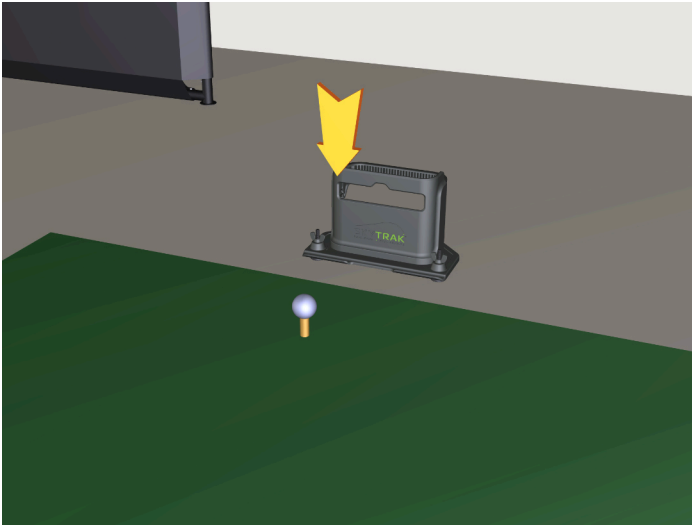

Step 58

Position the Shield centered with the opening facing the golf ball and turf as shown.

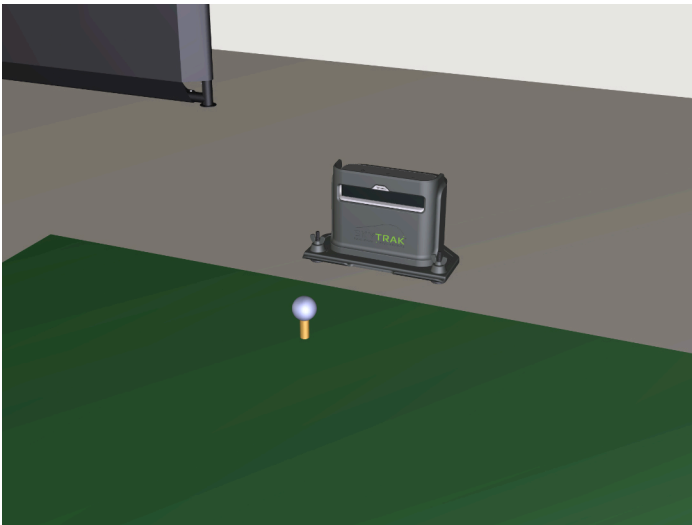

Step 59

Insert the SkyTrak+ into the Shield. Ensure the laser on the SkyTrak+ is facing the opening of the Shield.

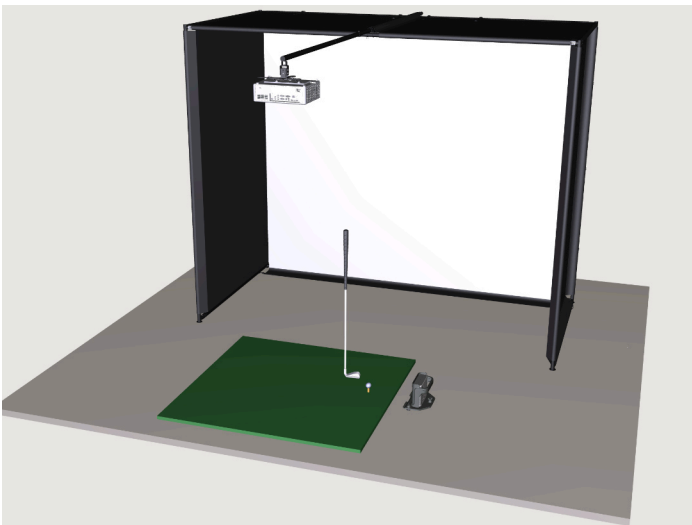

Step 60

WARNING: Ensure the Projector is not in the path of the golf club when it is swung.

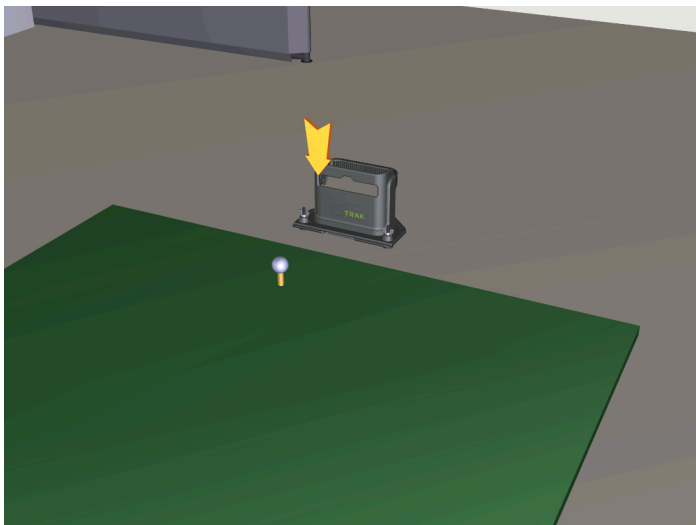

Step 61

Congratulations, this completes the assembly of the Golf Simulator Par 5 Short Enclosure.